



IMPORTANT INFORMATION

This unit should be installed by a qualified competent person in accordance with all relevant legislation and regulations including building regulations and wiring regulations BS7671. If in doubt contact a qualified competent person.

- Turn off all power supplying this equipment before working on or inside the equipment.
- Always use a properly rated volt-sensing device to confirm the power is off.
- Replace all devices, doors and covers before turning on the power to this equipment.
- To avoid ingress of swarf and similar material, always remove gland plates to allow cutting/slotting for cable entries.

Failure to follow these instructions could result in serious injury or death.

DO NOT USE POWER TOOL SCREWDRIVERS ON ELECTRICAL CONNECTIONS

Fitting & Wiring Instruction

- Remove door and shield assembly
- Remove the gland plates from the bottom of the distribution board.
- Install the meter kit by referring to Fig. 1.

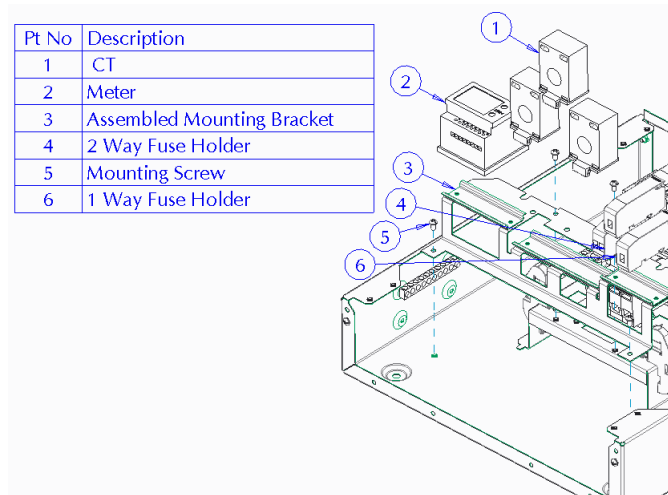

Fig. 1

If the incoming cables are too long cut the cable to length ensuring the cable markers remain on both ends of the cable. Use pads and cable ties to secure cable. Fully tighten terminal cages and cable clamps to torque as recommended in the tightening torque table from instruction leaflet supplied with the board.

Wiring Instruction

Connect the meter to the CT's and fuses by referring to the wiring diagram in fig. 3 for standard meter wiring and fig. 4 for MID meter wiring.

- Connect CT loom from meter to CT terminals.
- To access CT terminals slide the CT top cover aside.

Both STD and MID power wiring will be terminated to the balcony terminals on the outgoing side of the switch disconnecter, see fig. 2 for more information.



Fig. 2

Re-fitting Instruction

- Refit the gland plate.
- Refit the shroud to the top of the busbars/ over the interconnections.
- Before fitting the front cover, check the tightness of **all** connections, including factory made connections.
- Remove the appropriate knockout(s) in the cableway front plate and refit to box.

Meter setup Instruction

- Refer to meter instructions to set up meter.
- For **Standard** meter CT ratio to be set to 25 for 125/5A CTs.
 For **MID** meter CT ratio is **factory set** to 25 for 125/5A CTs

NOTE! Parts of the installation in which the meter kit is to be installed may remain live even when isolated. When working on unit FULLY open all meter fuses.

Affix supplied fuse warning labels in a clearly visible area in the following places 1) beneath or next to meter fuses and 2) beneath or next to isolator on front shield.



Standard Meter Kit wiring

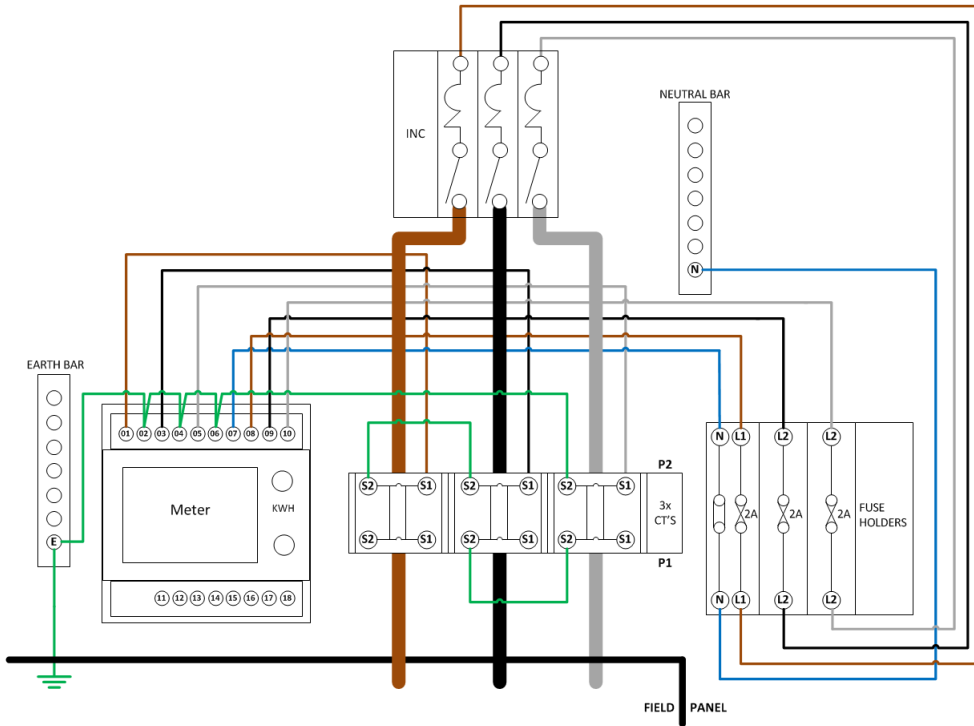

Fig. 3

MID Meter Kit wiring

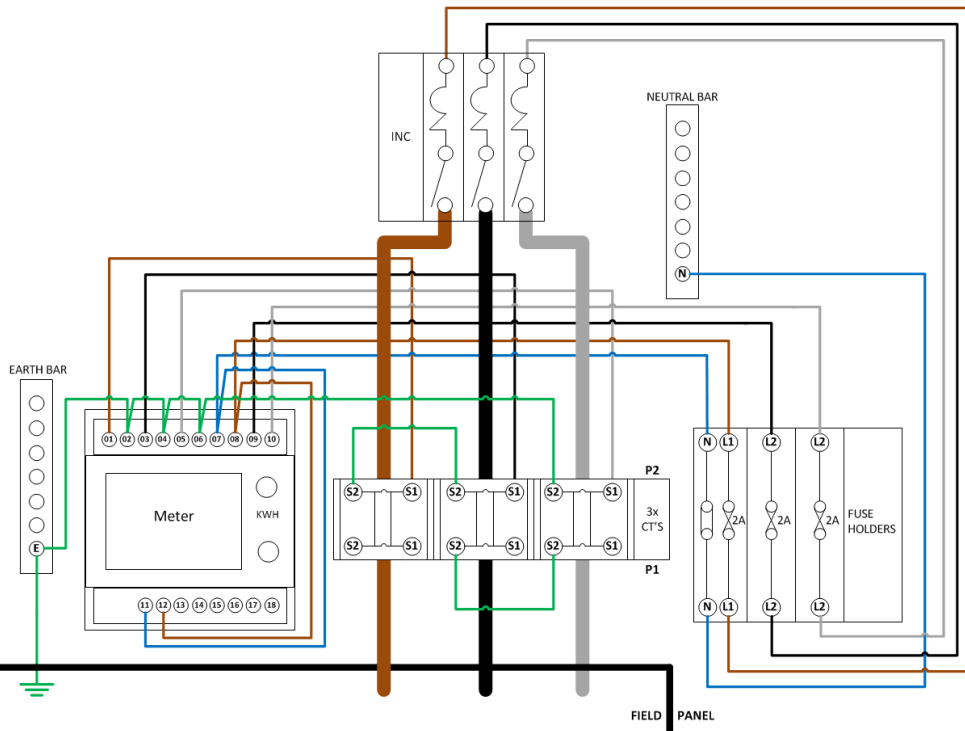

Fig. 4