



This kit should be installed by a qualified competent person in accordance with all relevant legislation and regulations including building regulations and wiring regulations BS7671. If in doubt contact a qualified competent person.

- Turn off all power supplying this equipment before working on or inside the equipment.
- Always use a properly rated volt-sensing device to confirm the power is off.
- Replace all devices, doors and covers before turning on the power to this equipment.
- To avoid ingress of swarf and similar material, always remove gland plates to allow cutting/slotting for cable entries.

Failure to follow these instructions could result in serious injury or death.

DO NOT USE POWER TOOL SCREWDRIVERS ON ELECTRICAL CONNECTIONS

Fitting Instruction

- Remove the door and front plate from the main panel board & cableway.
- Assemble the corner way ready to be attached to the cableway / spreader box by using two screws (No. 10 x 1/3") provided with the kit. Refer to the image in Fig 1 for more details.

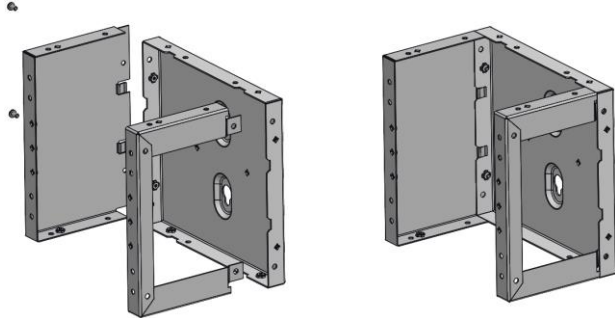

Fig 1

- Once the enclosure is assembled attach the unit to the cableway and spreader box using the M6 nuts, bolts and washers provided in the kit.
- Image shown in Fig 2 demonstrates the box attaching from the left-hand side only, reverse the process for the right-hand side.

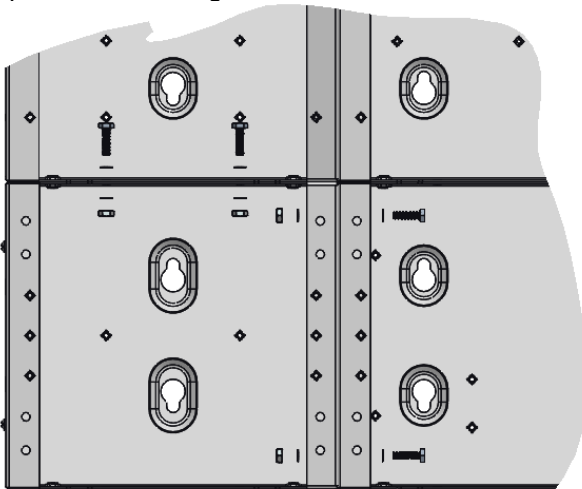

Fig 2

- Fit the gland and front plate to the corner box using the screws (No. 10 x 1 3/8" and No. 10 x 1/3") provided in the kit.

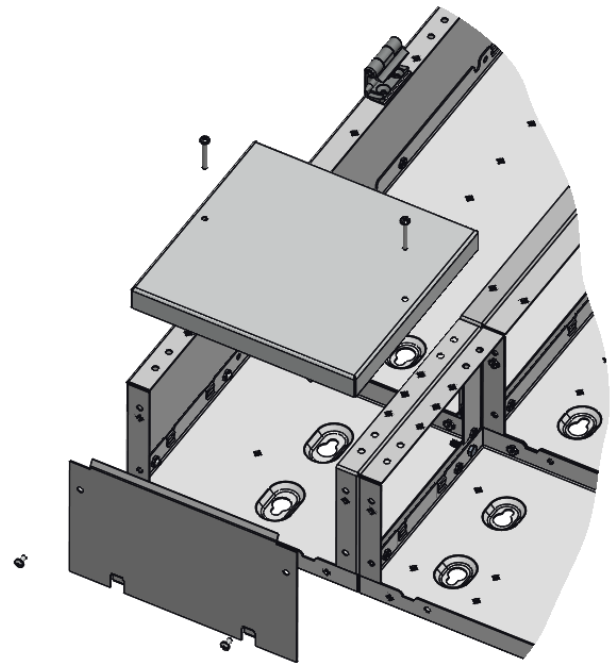

Fig 3

Re-fitting Instruction

- Before fitting the front cover & door to the main panel board, check the tightness of **all** connections, including factory made connection