



IMPORTANT INFORMATION

This unit should be installed by a qualified competent person in accordance with all relevant legislation and regulations including building regulations and wiring regulations BS7671. If in doubt contact a qualified competent person.

- Turn off all power supplying this equipment before working on or inside the equipment.
- Always use a properly rated volt-sensing device to confirm the power is off.
- Replace all devices, doors and covers before turning on the power to this equipment.
- To avoid ingress of swarf and similar material, always remove gland plates to allow cutting/slotting for cable entries.

Failure to follow these instructions could result in serious injury or death.

DO NOT USE POWER TOOL SCREWDRIVERS ON ELECTRICAL CONNECTIONS

Fitting Instruction

Remove the front plate and the gland plates from the panel board.

Fit the 2P MCB at the top of the panelboard, on the same side as the meter. Refer to Fig. 1 for details.

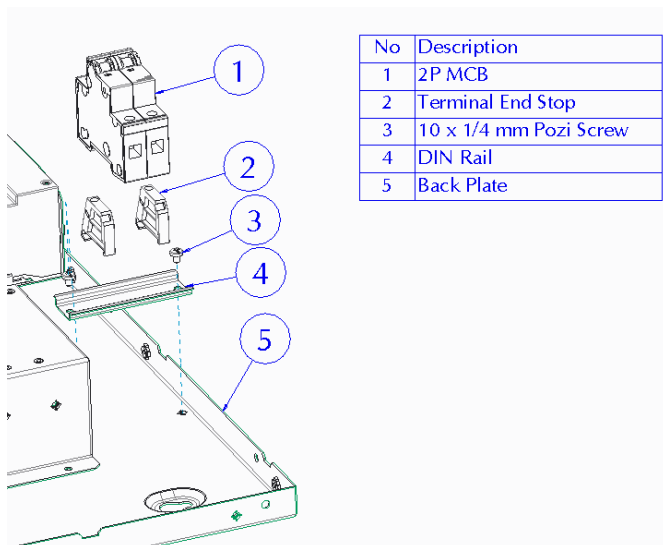

Fig. 1

Remove the shroud from the top end of the busbars.

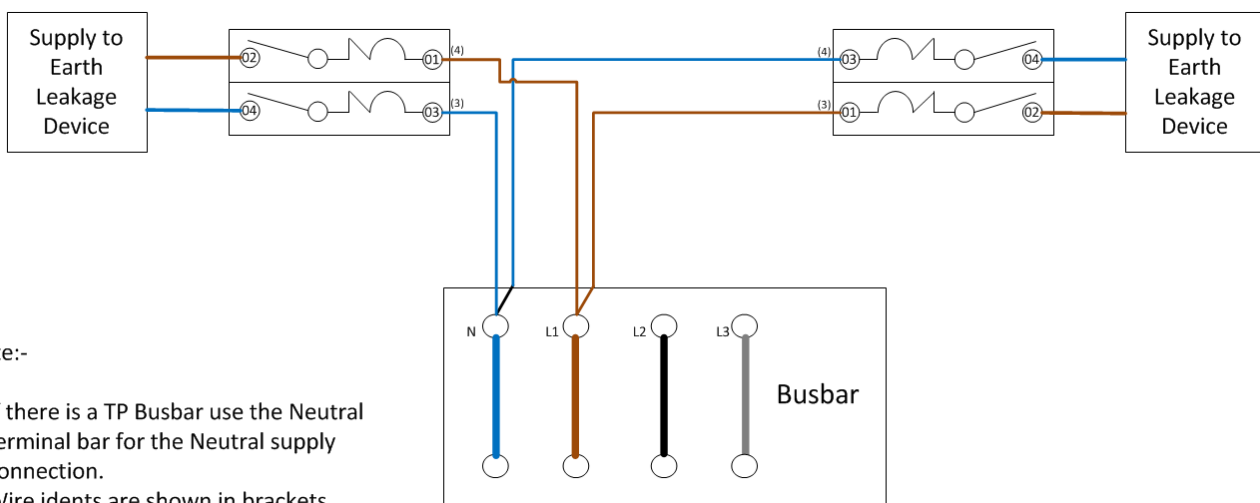

Fig. 2

Wiring Instruction

Connect the meter to the MCB's by referring to the wiring diagram in fig. 2.

Wire from the busbar to the MCB's using the M8 bolts and the 1.5mm single cable supplied in the kit.

If the busbar is a TP, run the Neutral cable down to the panel Neutral bar. Busbar connection recommended torque is 20 Nm & terminal bar 6 Nm, for any other torque settings refer to the manufacturers leaflet.

If the cables are too long cut the cable to length ensuring the cable markers remain on both ends of the cable. Use pads and cable ties to secure cable. Fully tighten terminal cages and cable clamps to torque as recommended in the tightening torque table.

Re-fitting Instruction

Before fitting the covers, check the tightness of all the connections.

Refit the gland plates and the front plates.