



Installation Instructions
Loadstar Modular Range
125A lighting and power
18ML125LP

Important

This unit should be installed by a qualified competent person in accordance with all relevant legislation and regulations including building regulations and wiring regulations BS7671. If in doubt contact a qualified competent person.

- **Turn off all power supplying this equipment before working on or inside the equipment.**
- Always use a properly rated volt-sensing device to confirm the power is off.
- Replace all devices, doors and covers before turning on the power to this equipment.
- To avoid ingress of swarf and similar material, always remove gland plates to allow cutting/slotting for cable entries to be effected remotely from the Distribution Board's Installation position.

Failure to follow these instructions could result in serious injury or death.

- Remove the top cross strap from the unit
- Remove the gland plates from the bottom of the distribution boards.
- Fit the unit below the MCB distribution board units using the M5 x 16 bolts, M5 contact washers and nuts supplied using the holes in the rear flange.
- Fit the long cross strap to the inside of the meter unit and the short cross straps to the inside of the distribution boards and bolt through boxes and straps to secure the front of the units (see diagram b on reverse).
- If necessary, cut cables to length. Fit heat shrink sleeve to cables for phase identification, then cut and strip insulation back 20mm and re-crimp with ferrules provided
- Connect the neutral cable (marked blue) to the distribution board neutral terminal clamp as shown.
- Connect the phase cables (marked brown, black and grey) to the mcb board isolator/direct connection unit terminals following the cable colours/marking (see diagram a).
- Fully tighten terminal cages and cable clamps to torque as recommended in the distribution board instruction leaflet.
- Refer to meter instructions to set up the meter. (Note meter CT ratio preset to 125/5A).
- **NOTE! Parts of the installation in which the meter kit is to be installed may remain live even when isolated. When working on unit FULLY open all meter fuses.**
Affix supplied fuse warning labels in a clearly visible area in the following places 1) beneath or next to meter fuses and 2) beneath or next to isolator on front shield.
- **NOTE! The maximum load on either MCB board is 100A. Affix supplied derating labels in a prominent position on each board.**

DO NOT USE POWER TOOL SCREWDRIVERS ON ELECTRICAL CONNECTIONS

Before fitting the front cover, check the tightness of **all** connections, including factory made connections.

NOTE: TOTAL MAXIMUM LOAD NOT TO EXCEED 125A.
BALANCE LOADS WITH THE HEAVIEST LOAD TO THE LEFT HAND SIDE OF
THE ASSEMBLY

Phase
Identified
Cables

N - Blue

L1 - Brown

L2 - Black

L3 - Grey

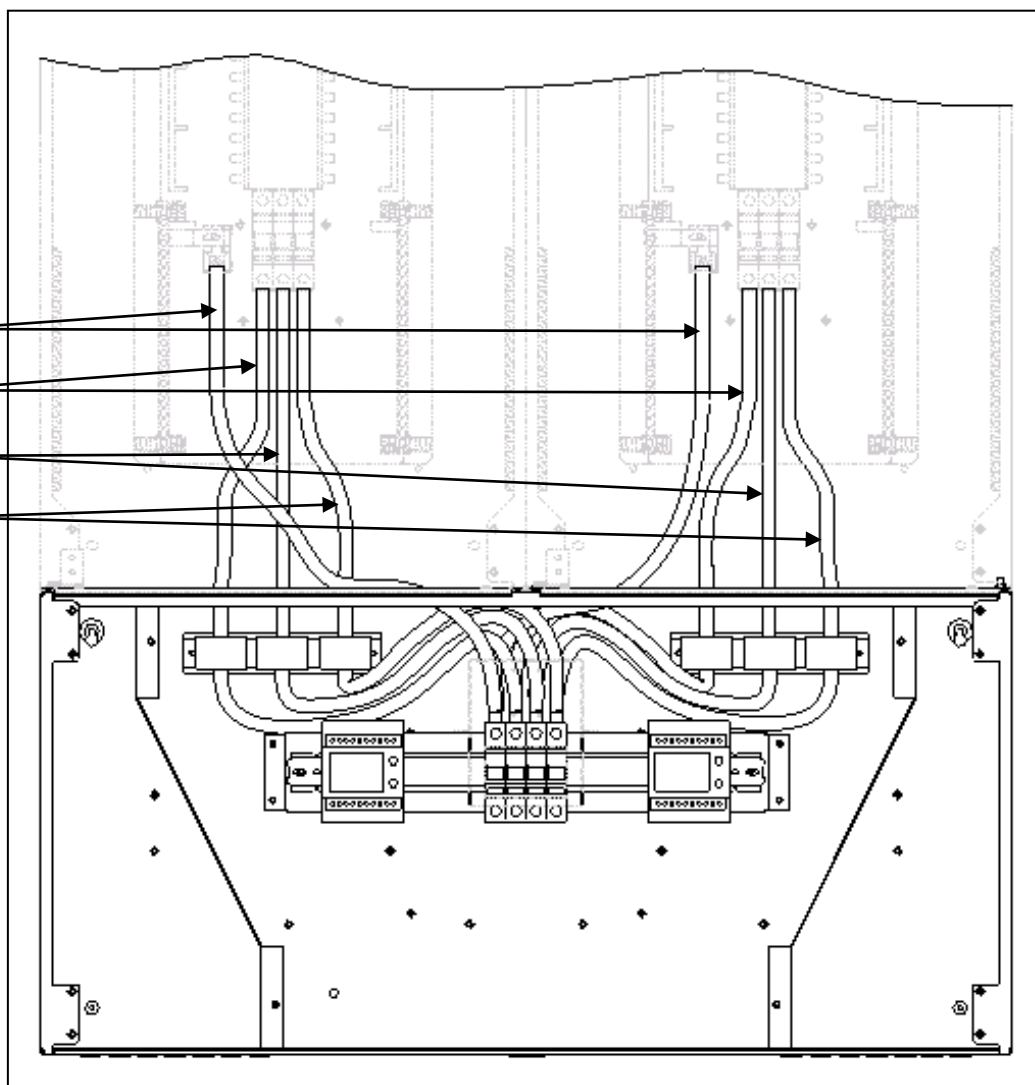

Diagram a. Cable connections.

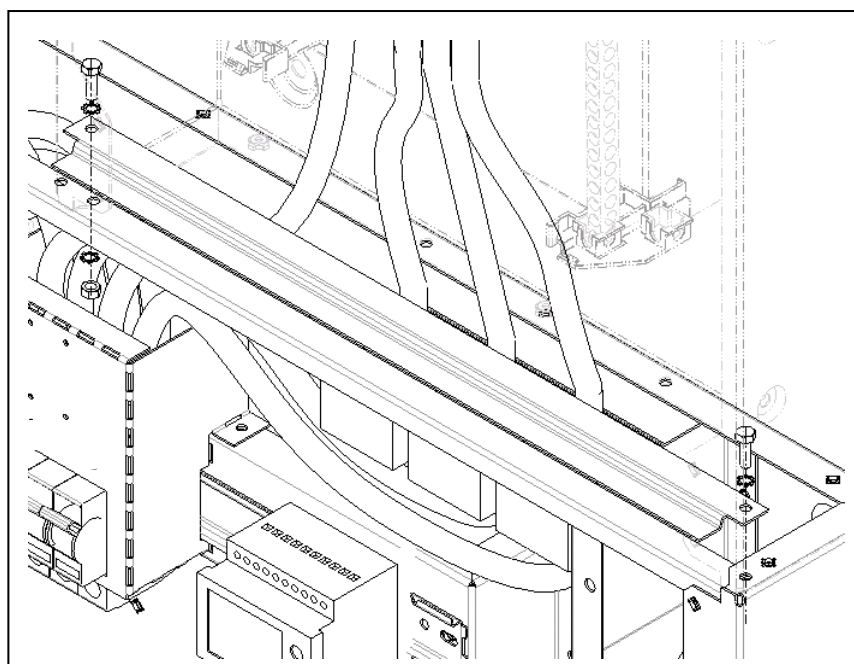

Diagram b Cross strap fixing



Electrium Sales Limited, Walkmill Lane, Cannock, WS11 0XE, England
Tel: 01543 455000 Fax: 01543 455001

