

	303/TS24	303/TQ7 303/TQ24
	230V~ 50Hz	230V~ 50-60Hz
	—	R100h / +25°C
	± 2 s/d +25 °C	
P	0,6 W	
	-10°C ... +55°C	
	-10°C ... +60°C	
	1 ... 4 mm ²	0,5 ... 2,5 mm ²
	8 mm	
	16A/250V~μ cos φ = 1	

Operating principle: Typ 1.B. S/R. T.
IEC/EN 60730-1, IEC/EN 60730-2-7
Operation in a normal environment
Montage: in distribution panel
Degree of contamination: 2
Switch output, potential-free

Safety notes

This product may be installed only by a qualified electrician. Non-compliance may result in a fire hazard or electric shocks. Before installation, read the operating instructions and observe the product-specific requirements for the installation location.

Use only original spare parts for repair and maintenance. Unauthorised opening and repair by other persons will invalidate all claims for liability, replacement or warranty services.

Disposal: Switch off the device before removing the battery.

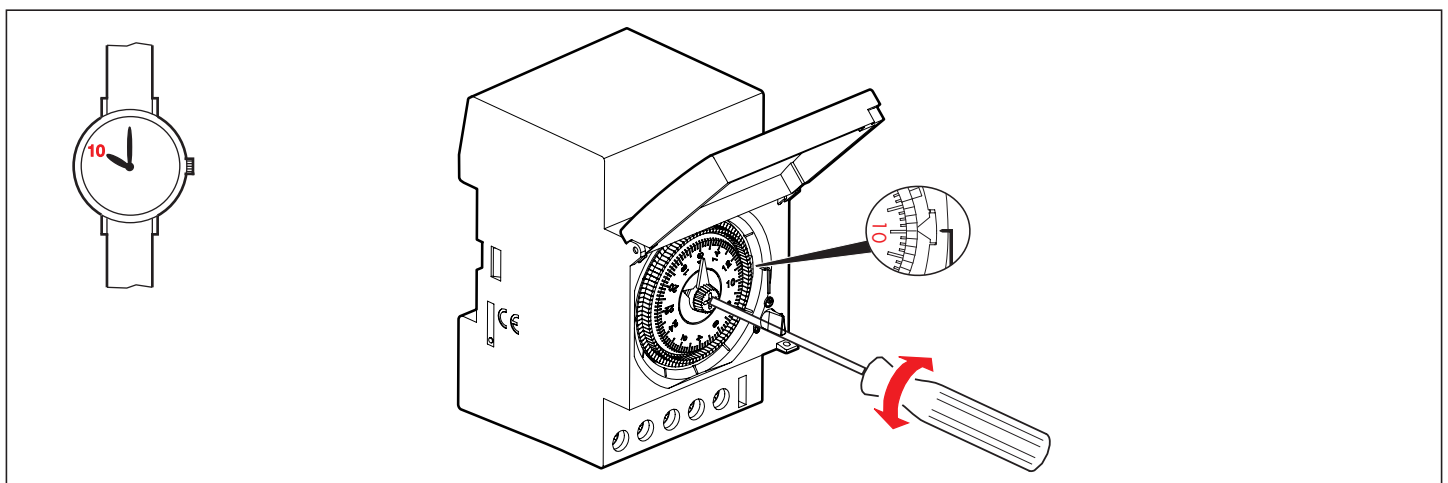
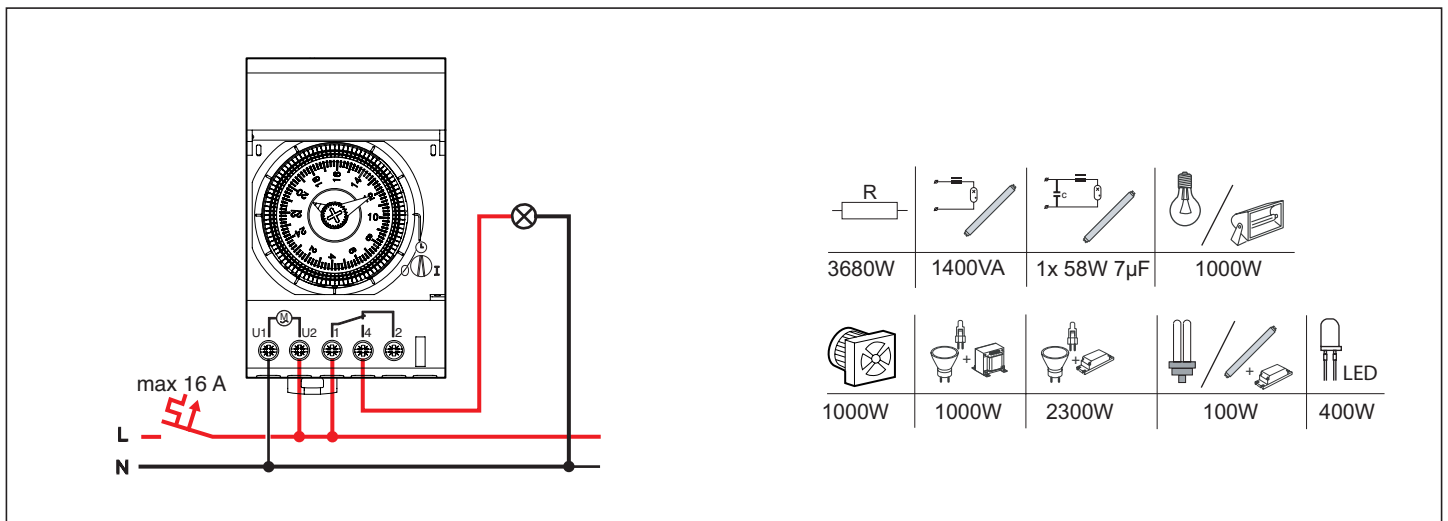

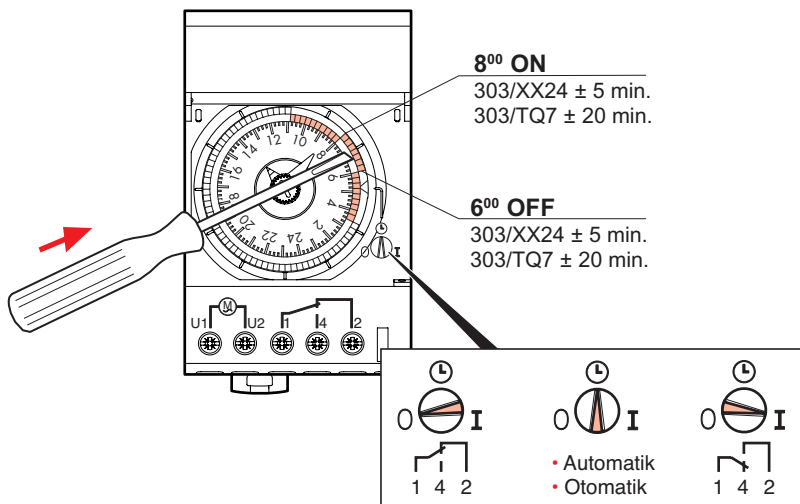

303/TS24
303/TQ24

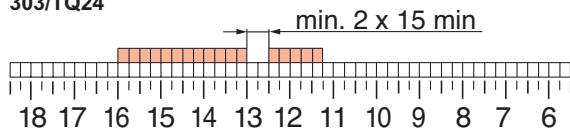

303/TQ7

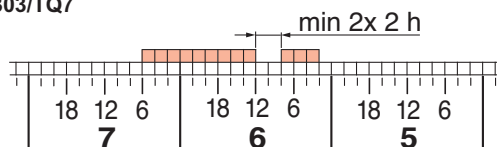

Disposal: Switch off the device before removing the battery.

