

SIEMENS

Installation Instructions for 8GP1856-0DA10

This unit should be installed by a qualified competent person, in accordance with all relevant legislation and regulations including buildings and wiring regulations BS7671. If in doubt contact a qualified person. After installation, tests must be completed in accordance with the requirements of the current edition of the IEE Wiring Regulations.

- 1) Remove polycarbonate shroud from the 8GP1856-0DA10 assembly.
Phase connections.
- 2) Loosen terminals on isolator to ensure the cage terminal clamps are **fully** lowered. Locate copper connections into isolator terminals and loosely secure.
- 3) Loosely fix the assembly mounting plate to the enclosure using fixing screws supplied.
- 4) Once all is correctly aligned, tighten isolator terminals to torque as shown in table below and tighten screws holding assembly to enclosure backplate.
- 5) Connect incoming Phase cables to the large terminal cage clamps and tighten to the recommended torque as shown in the table below.
Neutral connections
- 6) Remove the link between the incoming Neutral terminal and the Neutral terminal bar. Replace the *small* neutral clamp with the *large* clamp supplied loose with 8GP1856-0DA10.
- 7) Reconnect the link between the neutral terminal and terminal bar and tighten to torques as shown in the table below.
Completion
- 8) Refit shroud using screws supplied, ensuring the interphase barrier fits into the slots at the end of the shroud.
- 9) Connect incoming Neutral cable to the main neutral terminal cage clamp. Tighten as chart below.

Note

- Before fitting all shields and the front cover, check the tightness of **all** connections, **including** factory made connections.
- **DO NOT USE POWER TOOL SCREWDRIVERS ON ELECTRICAL CONNECTIONS**

TERMINAL	Max Cable Capacity	TORQUE Nm
ISOLATOR TERMINAL SCREWS	N/A	2.3Nm
NEUTRAL TERMINAL FIXING SCREW	N/A	2.3Nm
NEUTRAL TERMINAL BAR SCREWS	16mm ²	2.3Nm
TERMINAL CAGE GRUB SCREW	120mm ²	12Nm

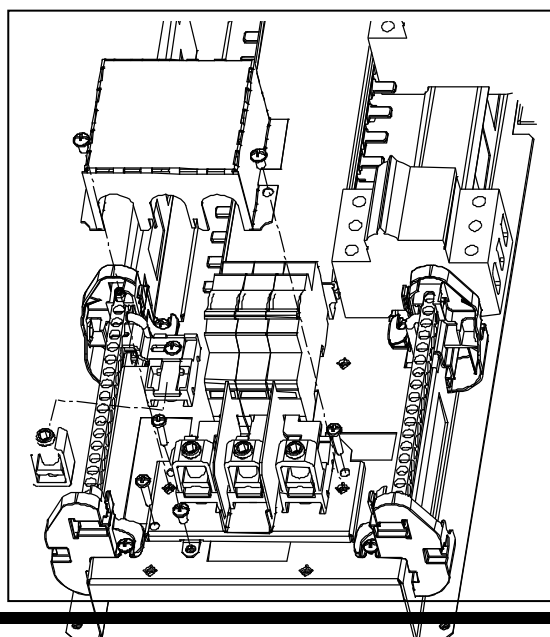

SIEMENS

Electrium Sales Limited, Sharston Road, Wythenshawe, Manchester, M22 4RA
Tel: 0161 998 5454 Fax: 0161 945 1587

UK
CA