



DANGER: LIVE PARTS ENCLOSED. Ensure the unit is installed by a qualified competent person in accordance with all relevant legislation and regulations including building regulations and wiring regulations BS 7671. If in doubt, contact a qualified competent person.



IMPORTANT INFORMATION

Follow the instructions below before working on or inside the equipment.



- Turn off all power supplies
- Always use a calibrated volt-sensing device to confirm the power is off.
- Replace all devices, doors and covers before turning on the power to this equipment.
- To avoid ingress of swarf and similar material, always remove gland plates to allow cutting/slotting for cable entries.
- Do not use power screwdrivers on electrical connections.



- **Failure to follow these instructions could result in serious injury or death.**

Installation Instructions for Fitting 8GP1904-0DA50 / 8GP1904-0DA51 SPD Kits in 125 A Distribution Boards

- Remove the front shield from the DB (Distribution Board).
- Fit DIN bracket to bottom left hand side of DB as shown in fig. 1.0. Use screws provided.
- Fit surge assembly onto DIN bracket, see Fig 1.1.
- Remove bottom left hand side knockout from DB shield. Place shield back onto the DB so that the surge arrester protrudes through the newly created aperture. Adjust the position of the surge arrester on the DIN bracket until the shield aligns with the DB enclosure. Remove shield and fix surge arrester at defined position using DIN clips provided.
- Connect the supplied MCB to the lower left hand side busbar position as shown in Wiring Diagram - Fig. 2. Torque as per DB instruction leaflet.
- Connect the brown marked cable between the L1 phase of MCB and L1 terminal of surge device, black marked cable between L2 terminals and grey marked cable between L3 terminals as shown in Fig. 2.
- Connect the blue marked cable between the DB neutral bar and the surge arrester neutral terminal as shown in Fig. 2
- Connect the green and yellow earth cable between the DB earth bar and the surge arrester earth terminal (see Fig. 2). Preferable connection point is onto the terminal bar where the incoming earth cable is connected.
- Fully tighten all connections to the torque settings as recommended in the distribution board instruction leaflet and surge device leaflet.
- NOTE - Disconnect the supply to the device or unplug the protective module before performing an insulation measurement in the system. Otherwise, inaccurate measurements are possible. Reconnect the supply /re-insert the module into the base element after the insulation measurement.
- Before fitting the front shield, check the tightness of **all** connections, including factory made connections.
- Re-fit DB shield and place insulation testing label onto the shield (supplied with surge device), below the surge device.
- Switch on MCB supply to surge device.

Fig. 1.0

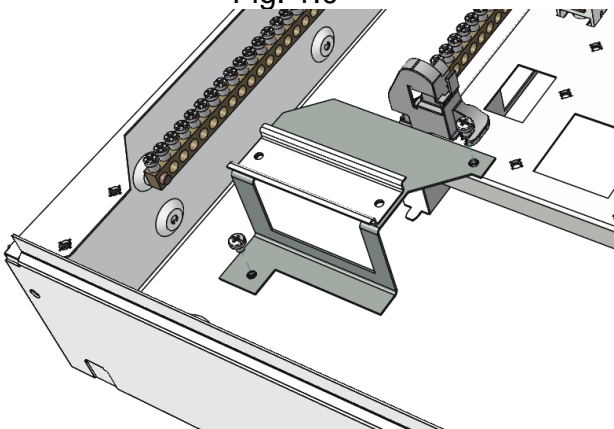
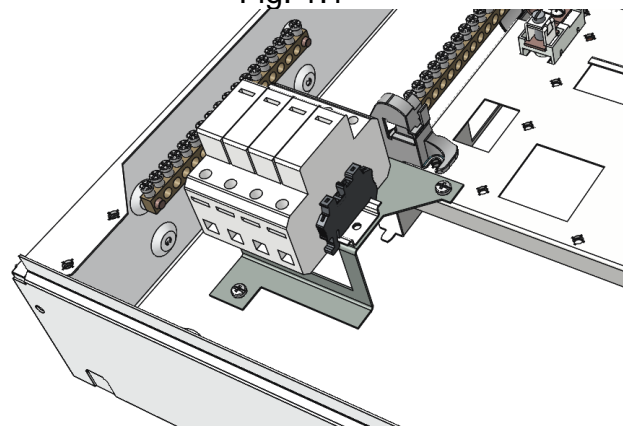
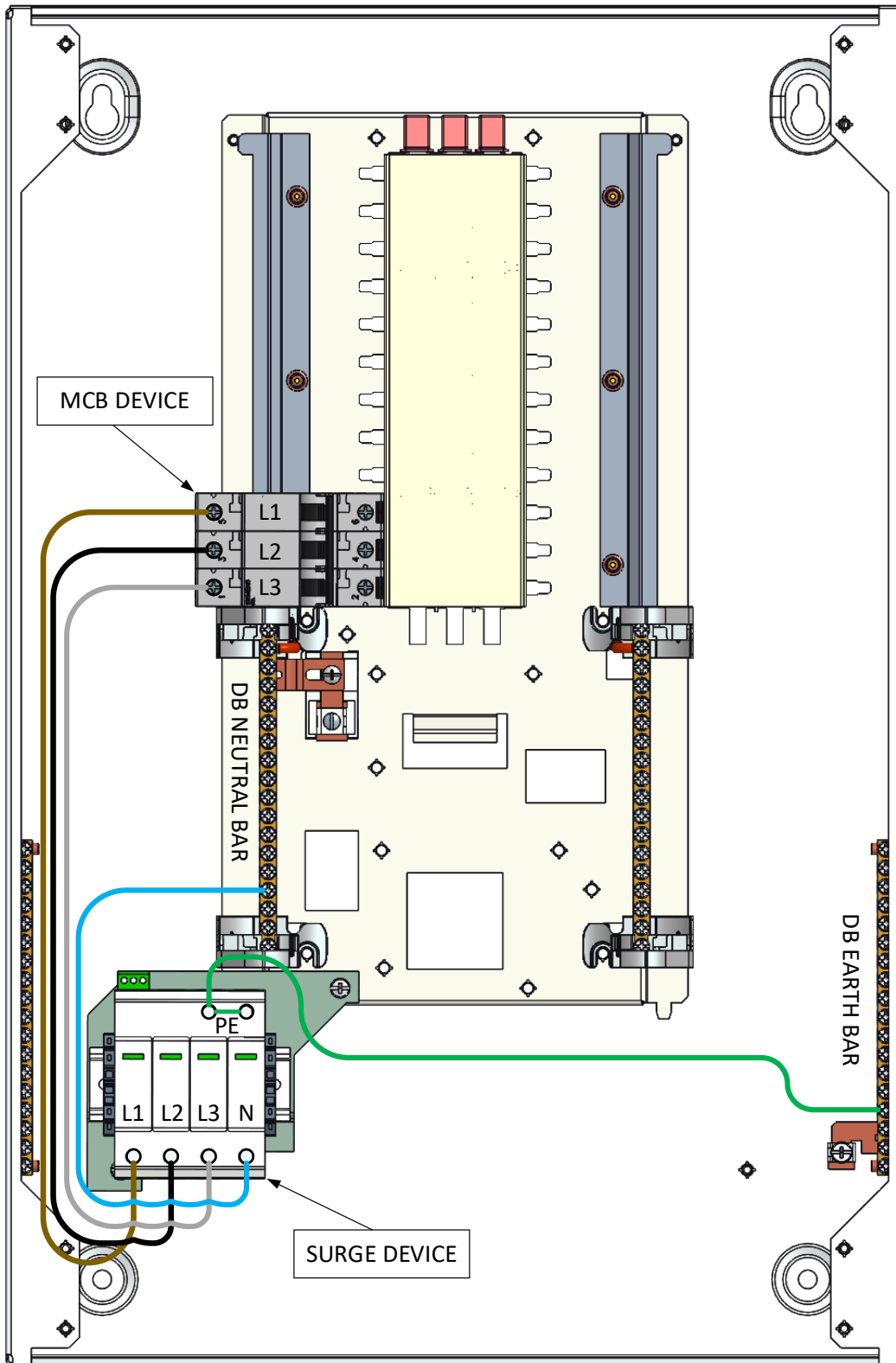

Fig. 1.1



- NOTE – for further instructions on surge device, replacement of the plug in module and more, please refer to surge device leaflet.



Wiring Diagram - Fig. 2



Installation Instructions for Fitting 8GP1904-0DA50 / 8GP1904-0DA51 SPD Kits, in 125 A L&P Boards

- Remove the front shield from the Main Incomer Enclosure.
- Cut the cables from the wiring loom provided with the SPD kit and shown on the Fig 4a according to the dimensions provided in the Fig. 4b. Crimp the appropriate cable with the ferrules provided with the SPD kit.
-

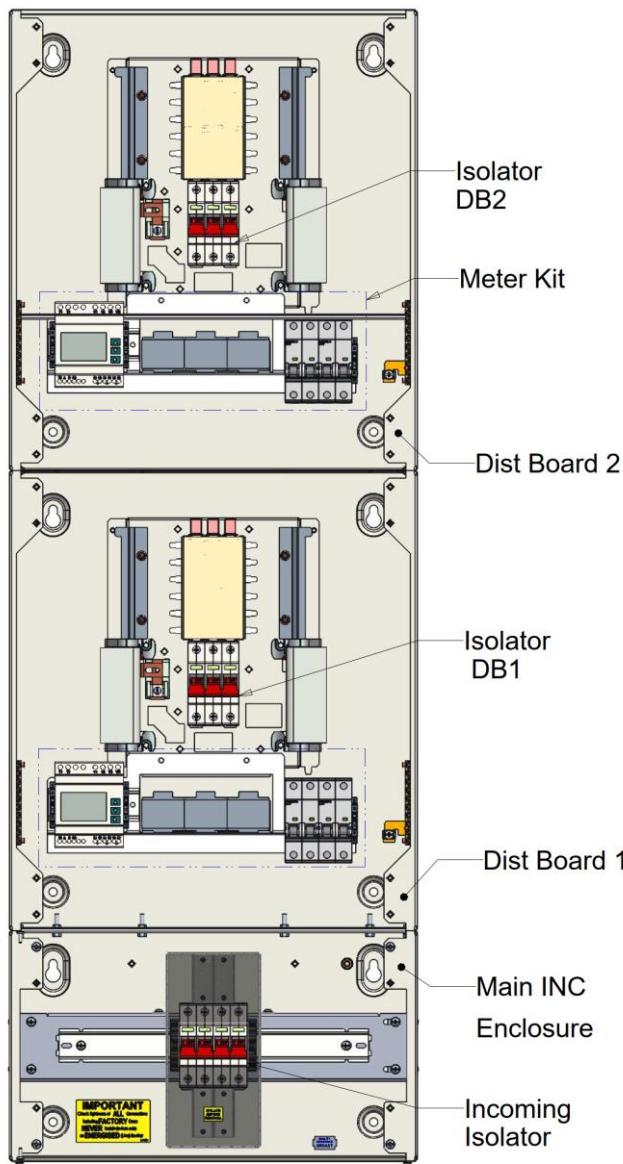

Fig 3.

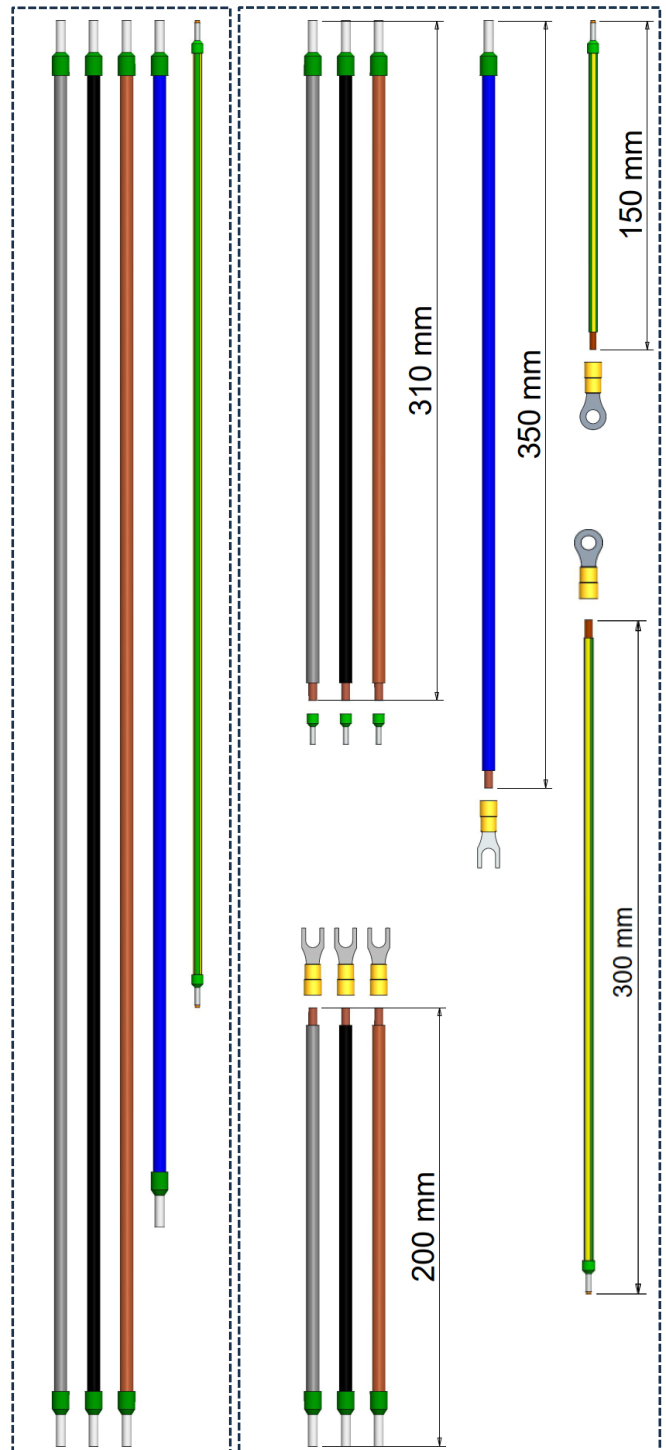
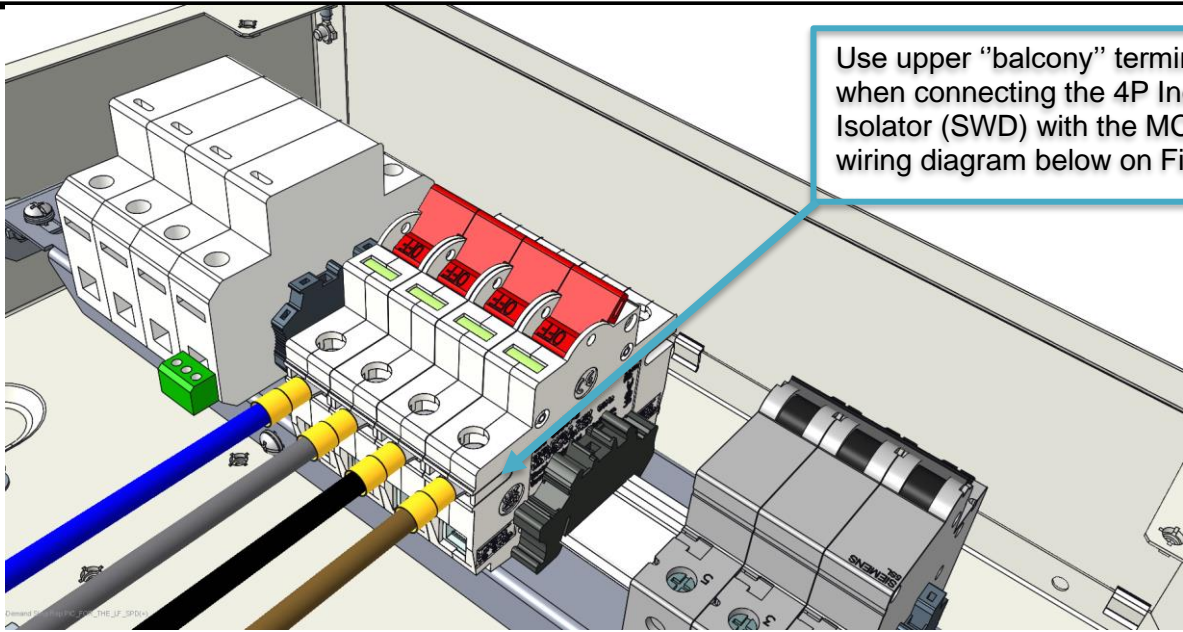

Fig. 4a

Fig. 4b



Use upper "balcony" terminals when connecting the 4P Incoming Isolator (SWD) with the MCB – see wiring diagram below on Fig. 6.

Fig. 5.

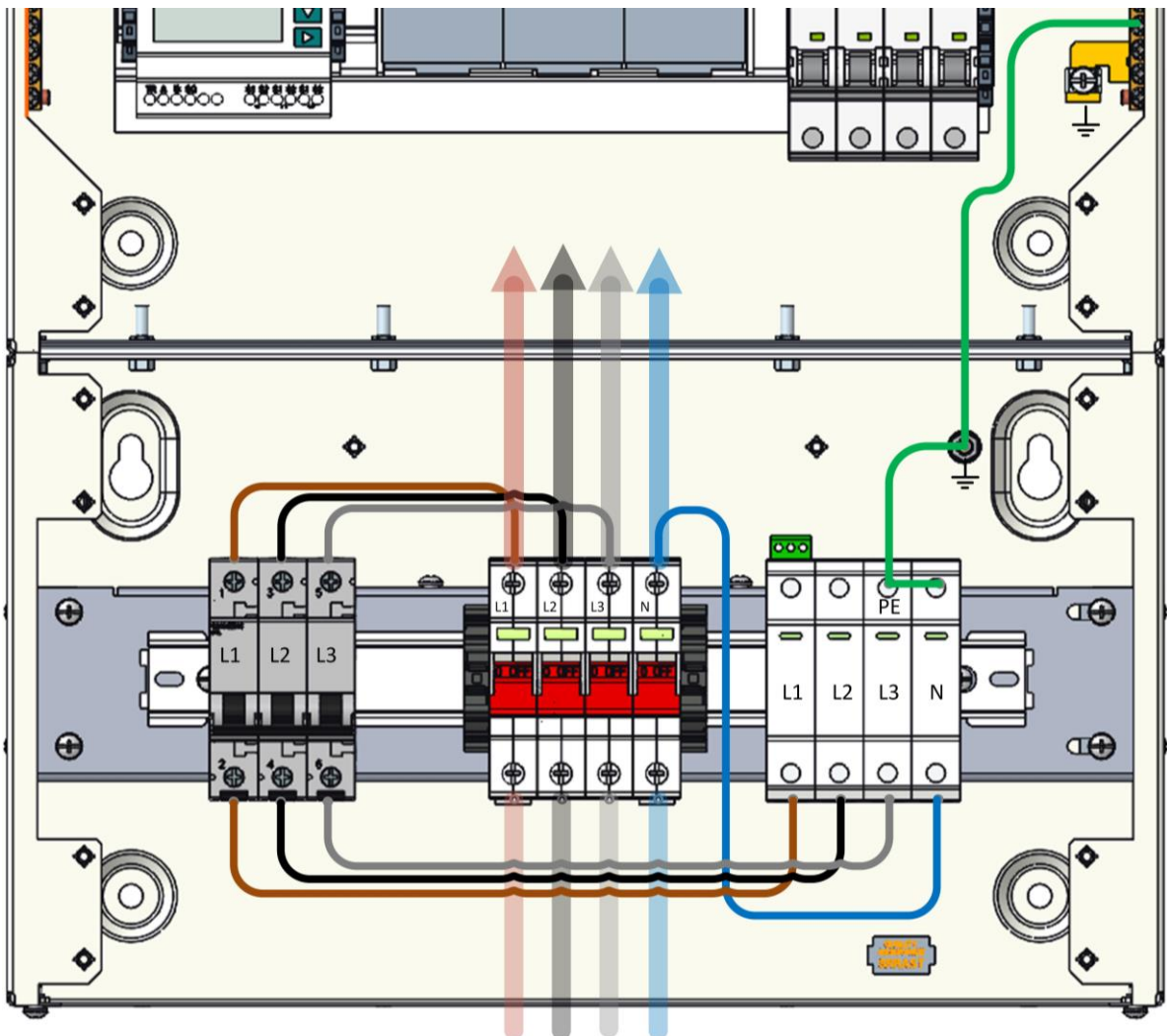

Wiring Diagram – Fig. 6



- Remove the Incoming Isolator Shroud and place the MCB and SPD devices onto DIN bracket, see Fig. 5. and Fig. 6.
- Adjust the position of the surge arrester and the MCB on the DIN bracket until the shield aligns with the Main Incomer Enclosure. Remove shield and fix surge arrester device and the MCB at defined position using DIN clips provided.
- Connect the Incoming Isolator to the top of the MCB as shown in Wiring Diagram on Fig. 5. And Fig. 6.
 - Cable Length for this connection in 200 mm – see Fig.4b.
- Connect the bottom of the MCB to the bottom of the SPD device as shown in Wiring Diagram on Fig. 6.
 - Cable length for this connection in 310 mm – see Fig.4b.
- Connect the Incoming Isolator Neutral lead to the bottom of the SPD, see the Wiring Diagram on Fig. 6.
 - Cable length for this connection in 350 mm – see Fig.4b.
- Connect the green & yellow earth cable between the SPD device and the Main Incomer Enclosure earthing point.
 - Cable length for this connection in 150 mm – see Fig.4b.
- Connect the green & yellow earth cable between Main Incomer Enclosure earthing point and the Main Distribution Board earthing point.
 - Cable length for this connection in 300 mm – see Fig.4b.
- **Fully tighten all connections to the torque settings as recommended in the Lighting and Power distribution board instruction leaflet, MCB leaflet and the surge device leaflet.**
- NOTE - Disconnect the supply to the device or unplug the protective module before performing an insulation measurement in the system. Otherwise, inaccurate measurements are possible. Reconnect the supply /re-insert the module into the base element after the insulation measurement.
- Before fitting the front shields, check the tightness of **all** connections, including factory made connections.
- Re-fit DB shields and Main Incomer Enclosure shields and place insulation testing label onto the shield (supplied with surge device), below the surge device.
- Switch on MCB supply to surge device.