



*This kit should be installed by a qualified competent person in accordance with all relevant legislation and regulations including building regulations and wiring regulations BS7671. If in doubt contact a qualified competent person.*

- Turn off all power supplying this equipment before working on or inside the equipment.
- Always use a properly rated volt-sensing device to confirm the power is off.
- Replace all devices, doors and covers before turning on the power to this equipment.
- To avoid ingress of swarf and similar material, always remove gland plates to allow cutting/slotting for cable entries.

**Failure to follow these instructions could result in serious injury or death.**

### **DO NOT USE POWER TOOL SCREWDRIVERS ON ELECTRICAL CONNECTIONS**

#### **Fitting Instruction**

- Remove the door and front plate from the main panel board & corner way if necessary.
- When fitting the spreader box refer to Fig. 1 for assembly details.
- Ensure that the assembly is fit for purpose by checking which end the kit is required.

#### **Re-fitting Instruction**

- Before fitting the front cover & door to the main panel board, check the tightness of **all** connections, including factory made connections.

**Fig. 1 – Spreader Box Assembly Detail**

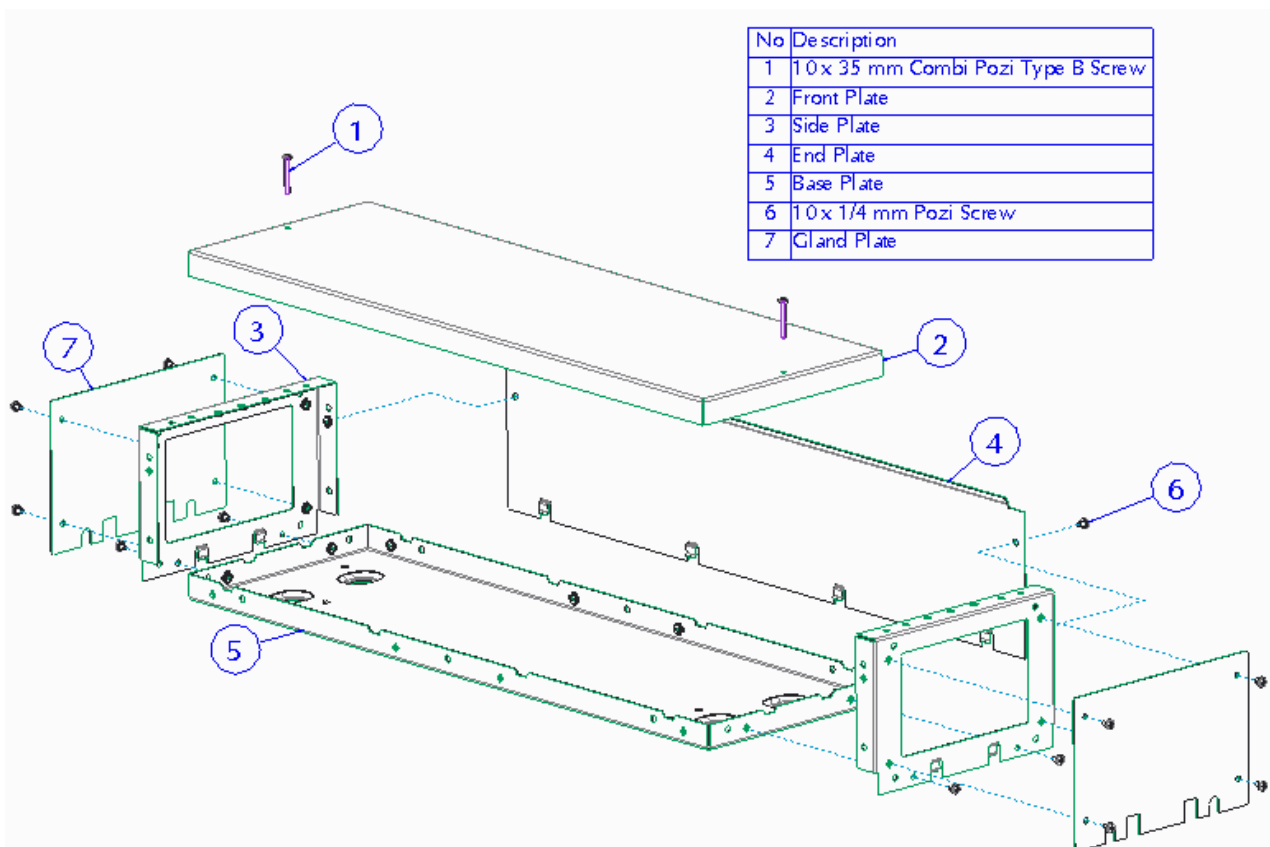

**NOTE: - Item 4 is not included with this kit  
but is supplied with the main Panelboard**