



This kit should be installed by a qualified competent person in accordance with all relevant legislation and regulations including building regulations and wiring regulations BS7671. If in doubt contact a qualified competent person.

- Turn off all power supplying this equipment before working on or inside the equipment.
- Always use a properly rated volt-sensing device to confirm the power is off.
- Replace all devices, doors and covers before turning on the power to this equipment.
- To avoid ingress of swarf and similar material, always remove gland plates to allow cutting/slotting for cable entries.

Failure to follow these instructions could result in serious injury or death.

DO NOT USE POWER TOOL SCREWDRIVERS ON ELECTRICAL CONNECTIONS

Fitting Instruction

- Before assembling the Add-on enclosure to the main panel, remove both the door and front shield & the bottom gland plate from the main panelboard.

To remove the door, refer to Fig. 1.

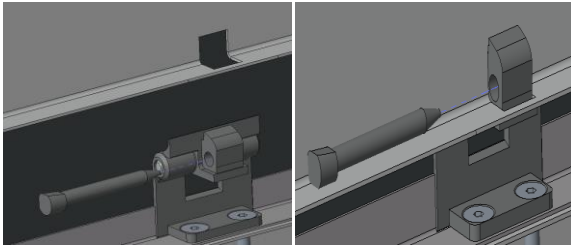

Fig. 1

- When the shield, door and gland plate have been removed, start to assemble the add-on enclosure to the panelboard by referring to Fig. 2.

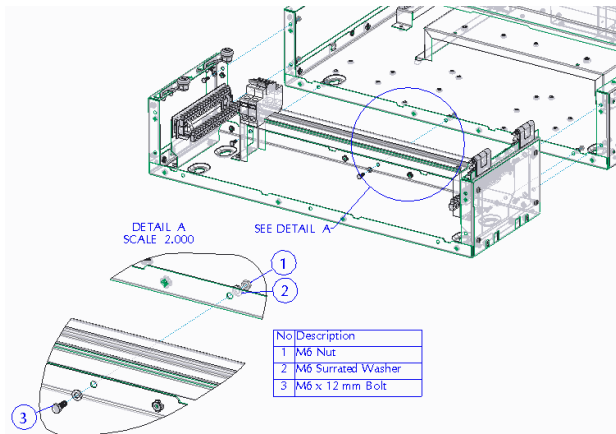

Fig. 2

- Re-use the bottom gland plate by attaching it to the bottom of the add-on enclosure. Refer to Fig. 3 for details.

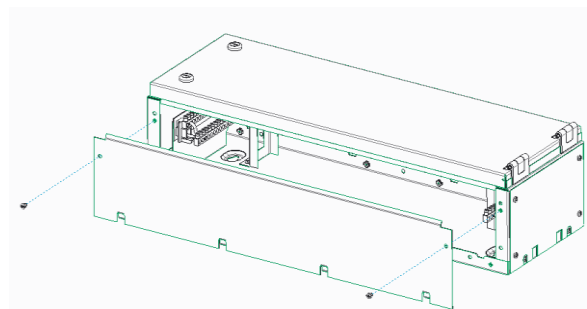

Fig. 3

- When the Add-on has been attached to the main panelboard, re-place the front shield by referring to Fig. 4.

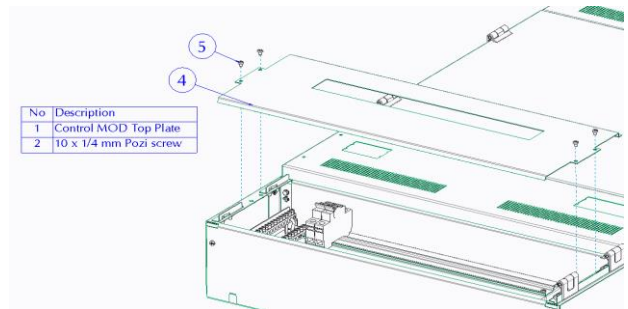

Fig. 4

- Attach the door by placing the pin into the hinge to secure the door, ensuring the head of the pin is positioned above the body of the hinge. Repeat this for all hinges. Refer to Fig. 5 for details.

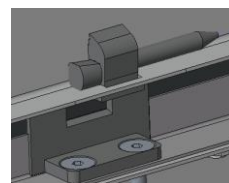

Fig. 5