



*This unit should be installed by a qualified competent person in accordance with all relevant legislation and regulations including building regulations and wiring regulations BS7671. If in doubt contact a qualified competent person.*

- Turn off all power supplying this equipment before working on or inside the equipment.
- Always use a properly rated volt-sensing device to confirm the power is off.
- Replace all devices, doors and covers before turning on the power to this equipment.
- To avoid ingress of swarf and similar material, always remove gland plates to allow cutting/slotting for cable entries.

**Failure to follow these instructions could result in serious injury or death.**

### **DO NOT USE POWER TOOL SCREWDRIVERS ON ELECTRICAL CONNECTIONS**

**NOTE: - THE APERTURE OF THE CT IS 28mm DIAMETER OVERALL.**  
**Please ensure that incoming cable will pass through this before continuing.**

### **Fitting Instruction**

Remove the front plates and gland plates from the cableway and distribution board

Assemble the CT by referring to Fig. 1. Ensure the polarity is correct (P1 supply to CT, P2 load from CT). Use No.10 x ¼ pozi screws to fasten the DIN rail to the CT bracket and the bracket cableway backplate.

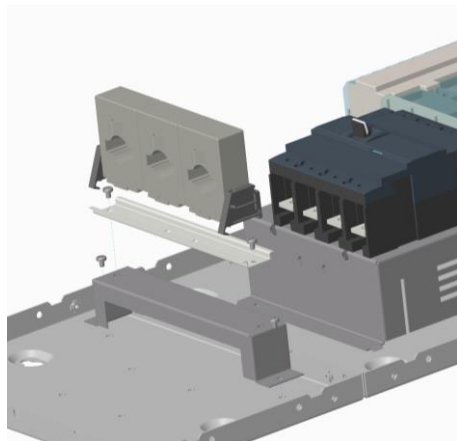

**Fig. 1**

Remove the knockout on the cableway to allow the meter to be mounted, ensure there are no sharp edges after removal. Refer to Fig. 2 for details.

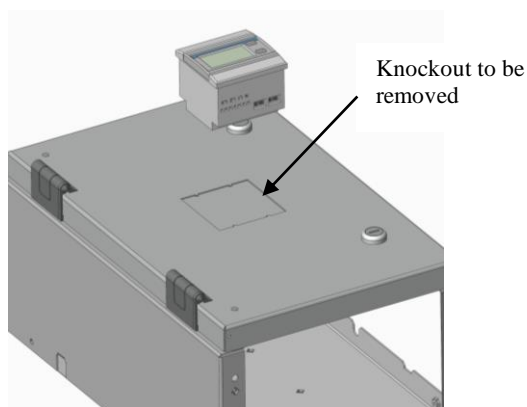

**Fig. 2**

Place the display unit into the exterior of the hole formed in the cableway. Ensure the orientation is correct, and gently push the display into the cableway until you hear the “clicks” of the tabs. This should indicate that the meter is fitted correctly.

Fit the 4P MCB required for the meter voltage connections by referring to leaflet supplied with the voltage supply loom & the wiring diagram in Fig. 3. Remove the shroud from the top end of the busbar to gain access. Connect the MCB to the Busbar using the voltage supply loom kit.

**VOLTAGE SUPPLY LOOM SOLD SEPERATLY CATALOGUE NO. 17VMVSLK**

### **Wiring Instruction**

Using the cable loom provided connect the meter to the MCB by referring to the wiring diagram in Fig. 3. If the cables are too long cut the cable to length ensuring the cable markers remain on both ends of the cable. Connect the CT to the meter using the cable loom provided.

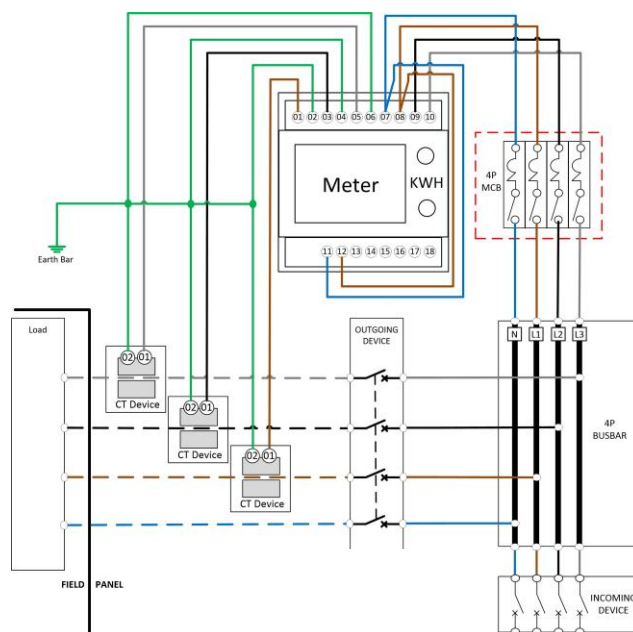

**Fig. 3**



## Installation Instructions

Meter Pack MID  
250A outgoing CT operated meter  
17VM250MKMID



Use pads and cable ties to secure cable. Fully tighten terminal cages and cable clamps to the torque as recommended in Fig.4.

Recommended Tightening Torques	
Fastener	Torque
Busbar End	15 Nm
MCB Device	See Manufacturers Leaflet for Recommended settings

Fig. 4

### **Re-fitting Instruction**

Refit the gland plate. Refit the shroud to the top of the busbars over the copper connections.

Before fitting the front cover, check the tightness of **all** connections, including factory made connections.

