



This kit should be installed by a qualified competent person in accordance with all relevant legislation and regulations including building regulations and wiring regulations BS7671. If in doubt contact a qualified competent person.

- Turn off all power supplying this equipment before working on or inside the equipment.
 - Always use a properly rated volt-sensing device to confirm the power is off.
 - Replace all devices, doors and covers before turning on the power to this equipment.
 - To avoid ingress of swarf and similar material, always remove gland plates to allow cutting/slotting for cable entries.
- Failure to follow these instructions could result in serious injury or death.***

DO NOT USE POWER TOOL SCREWDRIVERS ON ELECTRICAL CONNECTIONS

Fitting Instruction

- Remove the door and front plate from the main panel board
- Remove the Side plates from the main panel board
- Remove the front plate from the Corner way and spreader box if required.
- Assembling the back plate and side rails to the Main Panel board by Refer to Fig. 1 & Fig. 6 for details.

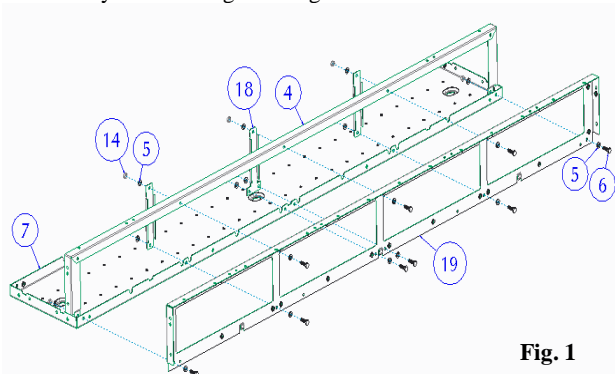

Fig. 1

Note: - Part number 19 does NOT come with this kit. This part is just for illustration purposes only.

- Once the Cableway is attached to the main panel board start to assemble the side plates by referring to Fig. 2 & Fig. 6.

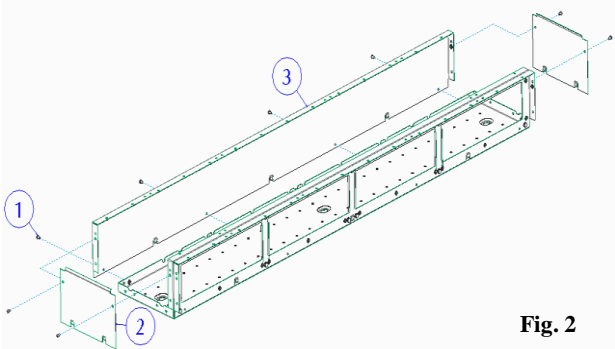

Fig. 2

- After the Cableway box is assembled start adding the hinges and latches, refer to Fig. 3 & Fig. 6 for details.

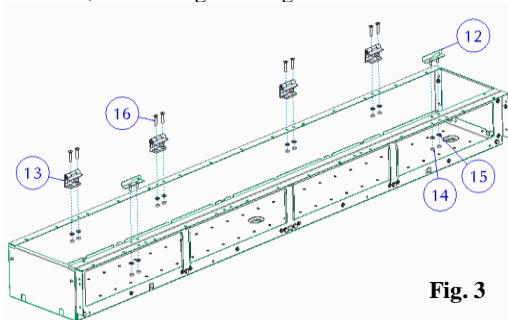

Fig. 3

- Next add the front plates by referring to Fig. 4 & Fig. 6.

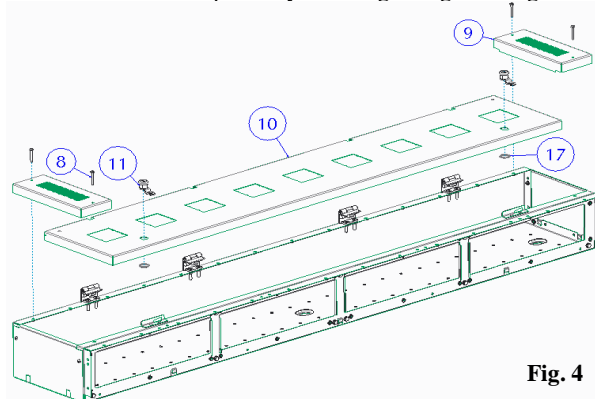

Fig. 4

- When fitting the door ensure that the following steps are followed in Fig. 5. First step place the door into the hinge as shown below.

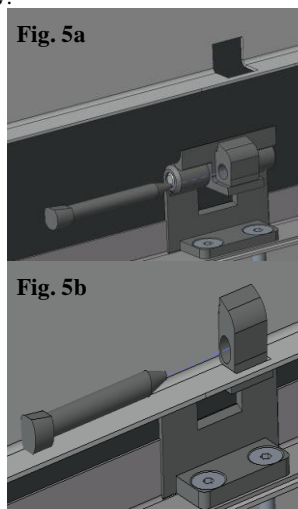

Fig. 5a

Fig. 5b

- Secondly place the pin into the hinge to secure the door in place. Ensure the pin is pointing downwards when fitting. Repeat this for all hinges.

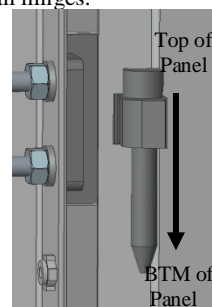

Fig. 5c



- Part descriptions and number are shown in Fig. 6.

No	Description
1	10 x 1/4 mm PozI Screw
2	End Plate
3	Box Side Plate
4	Box Side Rail
5	M6 Contact Washer
6	M6 x 20mm Bolt
7	Back Plate
8	10 x 3.5 mm PozI Type B Screw
9	Top and Bottom Front Plate
10	Cableway Front Plate
11	Panel Lock
12	Panel Latch
13	Panel Hinge
14	M6 Full Nut
15	M6 Flat Washer
16	M6 x 12 mm Countersunk Screw
17	M18 Flat Nut
18	Cableway Support Bracket
19	Panel Side Plate

Notes:

- Item No18 will change in quantity and placement per each variation.
- This cableway can be installed as a left or right hand cableway. The assembly shown demonstrates the assembly for both sides.

Fig. 6

- Ensure that the assembly is fit for purpose by checking which side the kit is required.

Re-fitting Instruction

- Before fitting the front cover & door to the main panel board, check the tightness of **all** connections, including factory made connections.

