



This kit should be installed by a qualified competent person in accordance with all relevant legislation and regulations including building regulations and wiring regulations BS7671. If in doubt contact a qualified competent person.

- Turn off all power supplying this equipment before working on or inside the equipment.
- Always use a properly rated volt-sensing device to confirm the power is off.
- Replace all devices, doors and covers before turning on the power to this equipment.
- To avoid ingress of swarf and similar material, always remove gland plates to allow cutting/slotting for cable entries to be effected remotely from the Distribution Board's Installation position.

Failure to follow these instructions could result in serious injury or death

DO NOT USE POWER TOOL SCREWDRIVERS ON ELECTRICAL CONNECTIONS.

Fitting Instruction

- Remove the door and front plate from the main panel board
- Remove the Side plates from the main panel board
- Remove the front plate from the Corner way and spreader box if required.
- Assembling the back plate and side rails to the Main Panel board by Refer to Fig. 1 & Fig. 6 for details.

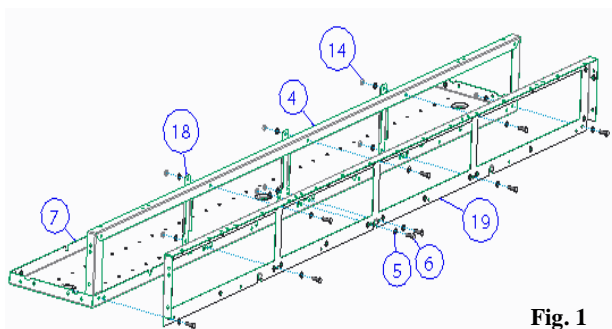

Fig. 1

Note: - Part number 19 does NOT come with this kit. This part is just for illustration purposes only.

- Once the Cableway is attached to the main panel board start to assemble the side plates by referring to Fig. 2 & Fig. 6.

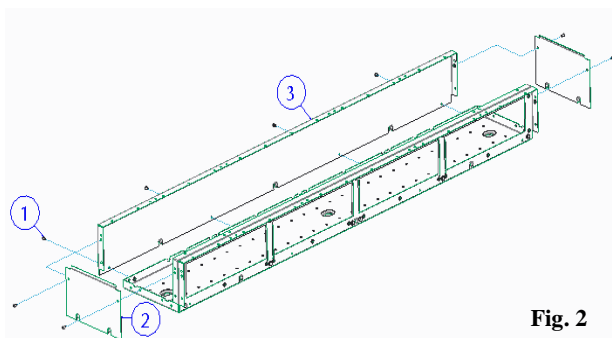

Fig. 2

- After the Cableway box is assembled start adding the hinges and latches, refer to Fig. 3 & Fig. 6 for details.

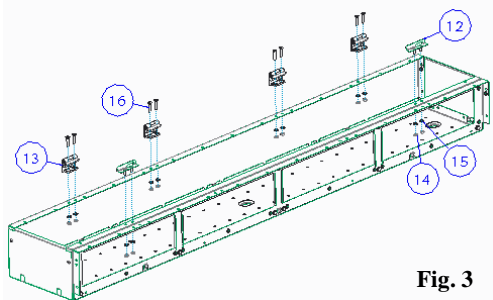

Fig. 3

- Next add the front plates by referring to Fig. 4 & Fig. 6.

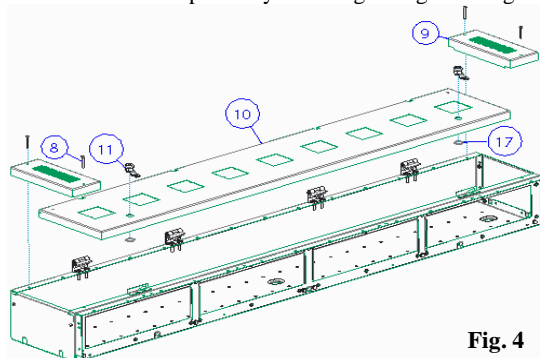

Fig. 4

- When fitting the door ensure that the following steps are followed in Fig. 5. First step place the door into the hinge as shown below.

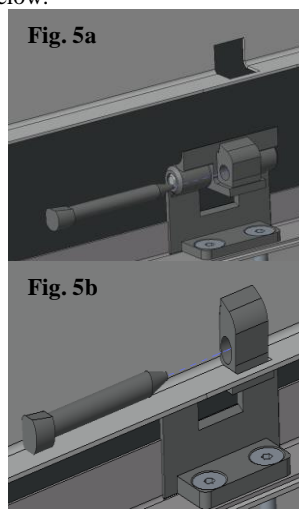

Fig. 5a

Fig. 5b

- Secondly place the pin into the hinge to secure the door in place. Ensure the pin is pointing downwards when fitting. Repeat this for all hinges.

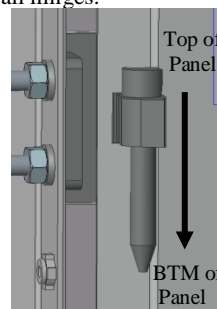

Fig. 5c



- Part descriptions and number are shown in Fig. 6.

No	Description
1	10 x 1/4 mm Pozl Screw
2	End Plate
3	Box Side Plate
4	Box Side Rail
5	M6 Contact Washer
6	M6 x 20mm Bolt
7	Back Plate
8	10 x 3.5 mm Pozl Type B Screw
9	Top and Bottom Front Plate
10	Cableway Front Plate
11	Panel Lock
12	Panel Latch
13	Panel Hinge
14	M6 Full Nut
15	M6 Flat Washer
16	M6 x 12 mm Countersunk Screw
17	M18 Flat Nut
18	Cableway Support Bracket
19	Panel Side Plate

Notes:

- Item No18 will change in quantity and placement per each variation.
- This cableway can be installed as a left or right hand cableway. The assembly shown demonstrates the assembly for both sides.

Fig. 6

- Ensure that the assembly is fit for purpose by checking which side the kit is required.

Re-fitting Instruction

- Before fitting the front cover & door to the main panel board, check the tightness of **all** connections, including factory made connections.

