



# Installation instructions



## Duplex Consumer Unit Temporary Locking Kit

**This Duplex locking kit is intended to temporarily lock off an entire duplex consumer unit. Follow the instructions below on how to fit the kit to the unit**

- a) With both visor lids closed, slightly lift the top visor and slide the T-shaped locking bracket in at an angle as shown.



- c) Now that the bracket is in position, depending on the diameter of the padlock shackle to be used, slide the U-Shaped locking bracket (with the correct hole in the tab) under the lip of the lid and through the cut-out in the T-shaped locking bracket.

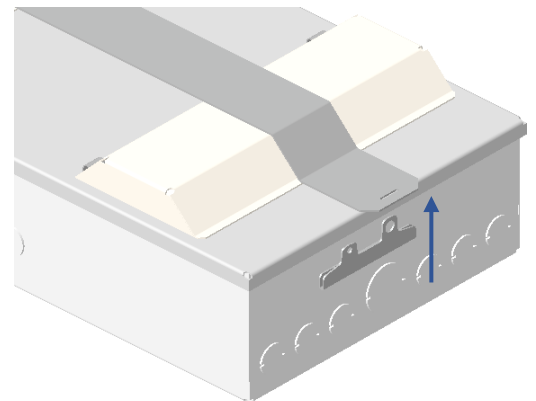

- b) Continue to slide the side of the T-shaped bracket under the visor until the bracket hangs vertically. Care should be taken to avoid scratching the lid.

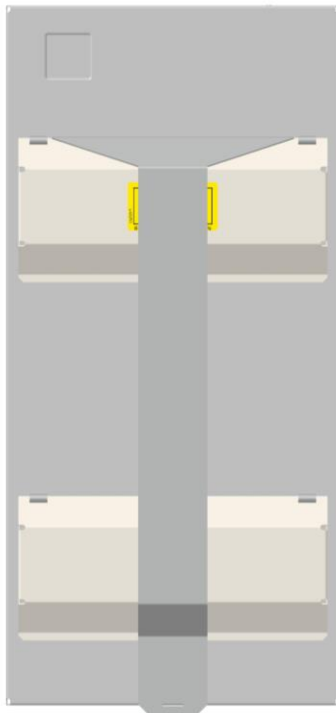

- d) Hold both brackets in position and insert the padlock shackle through the hole in the bracket and lock shut.

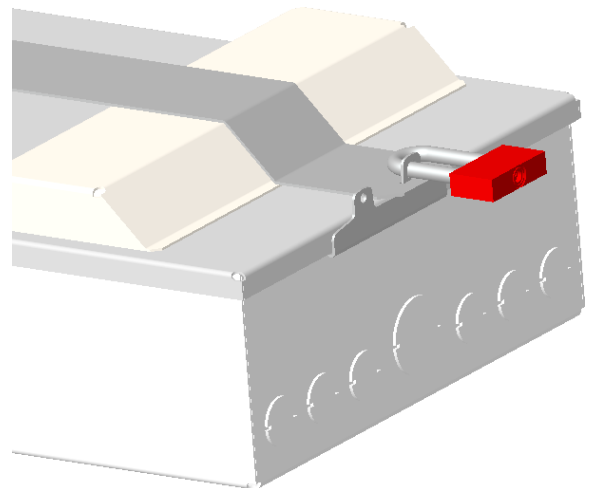

Note: This temporary locking kit is either compatible with a 3mm shackle padlock [sold separately – Cat Reference: WPL] or a 6.5mm shackle padlock (bought separately)

Care should also be taken when removing the brackets to avoid scratching the lid.

