



**THIS DEVICE IS NOT SUITABLE FOR DUAL RCD UNITS (For options contact Crabtree Technical)**

**IMPORTANT INFORMATION**

*This unit should be installed by a qualified competent person in accordance with all relevant legislation and regulations including building regulations and wiring regulations BS 7671. If in doubt contact a qualified competent person.*

- Turn off all power supplying this equipment before working on or inside the equipment.
- Always use a properly rated volt-sensing device to confirm the power is off.
- Replace all devices, doors and covers before turning on the power to this equipment.

***Failure to follow these instructions could result in serious injury or death.***

**DO NOT USE POWER TOOL SCREWDRIVERS ON ELECTRICAL CONNECTIONS**

### 1. Technical Information

BSI Standard	BSEN61643-11
Type Test Class	Type 2
Uc – Max. continuous operating voltage	275 VAC
Up – Voltage protection level (L-N), (N-PE)	1.3 kV
In – Nominal discharge current for class II	20 kA
I <sub>max</sub> – Maximum discharge current	40 kA
I <sub>sc</sub> – Short circuit current rating	25 kA
Degree of protection	IP20

### 4. Tightening Torque Values

Terminal	Tightening Torque
Neutral / Earth	1.2 Nm
RSC	0.25 Nm
Main Switch	2.3 Nm

Use No.2 Pozidriv Screwdriver (PZ2) for all terminals

It is good practice to check the tightness torque of all connections prior to re-fitting the enclosure or consumer unit cover

### 2. Circuit Diagrams for connection within consumer units (High Integrity)

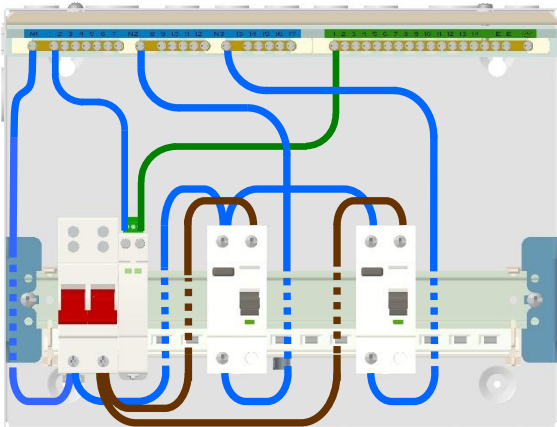

Note: Only Main Switch, High Integrity & Split Load units are compatible with this SPD kit. For Dual RCD contact Crabtree Technical for further details

### 3. SPD Cable connection sizes

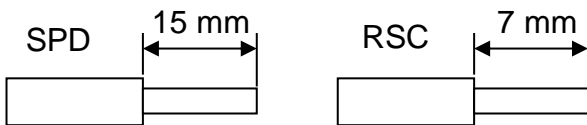

Terminal	Min. Cable Size	Max. Cable size
Neutral / Earth	∅ 2.5 mm sq*	∅ 10 mm sq
RSC	∅ 0.14 mm sq	∅ 1.5 mm sq

\* As per BS 7671 the minimum sized cable for a Type 2 SPD is ∅ 6mm sq. Neutral & Earth cables are supplied with this SPD. Use the crimp supplied on final termination of the prepared Earth cable.

### 5. SPD Wiring

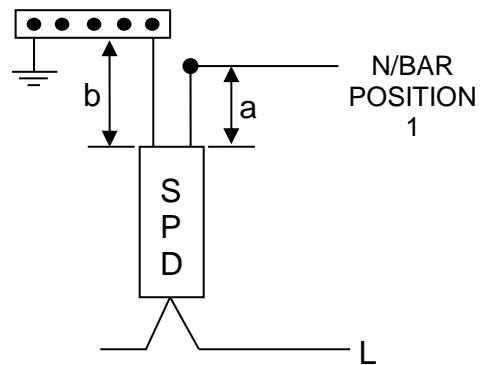

$a + b \leq 0.5 \text{ m}$  Recommended  
 $\leq 1 \text{ m}$  Maximum

### 6. Remote Signalling Contact (RSC)

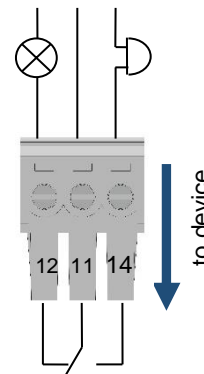

U <sub>max</sub> / I <sub>max</sub> a.c.	250 V / 0.5 A
U <sub>max</sub> / I <sub>max</sub> d.c.	30 V / 1.5 A



### 7. Connection to Starbreaker Busbar

SPD  
FITTED  
NEXT TO  
ISOLATOR

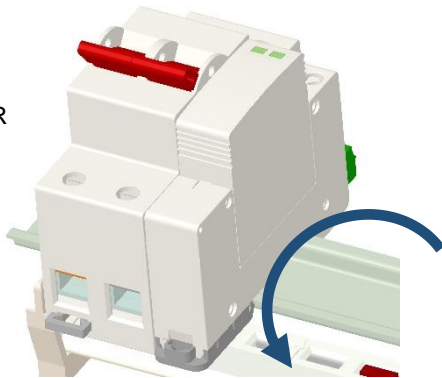

Place the SPD onto the top of the DIN rail and rotate to insert the prod into the busbar. The SPD should be fitted adjacent to the Isolator (Way 1.)

### 8. Reposition Consumer Unit Cover

Add circuit ways over-label (as supplied) and Icons where applicable. For other replacement parts e.g. Busbars contact Crabtree technical.

### 9. Cartridge Indication

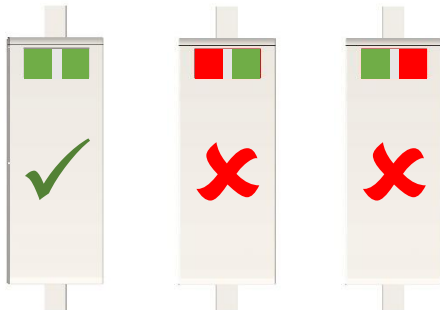

A full green window indicates a cartridge in good working order. Any red indication in the window means the cartridge is no longer working and must be replaced at the earliest opportunity.

### 10. Replacement Cartridge

The cartridge is fitted with internal overload protection and can take numerous surges before it will need to be replaced. For replacements contact your local wholesaler quoting the part number CRT2SPD/P

### 11. Cartridge Removal and Re-fitting

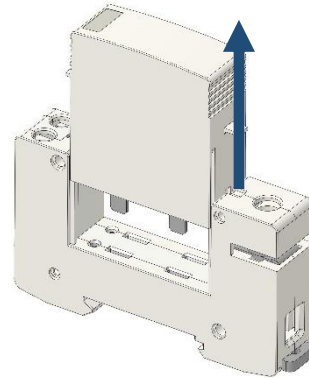

Remove the enclosure or consumer unit lid, slide the cartridge upwards from the base. Discard used cartridge in accordance with WEEE regulations.

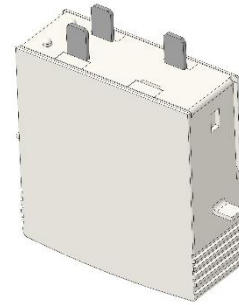

When fitting a new Cartridge care should be taken to align the two pips with the indents in the base module. The cartridge will only fit one way and should not be forced incorrectly. Ensure cartridge is inserted with no gaps to the base of the SPD.

### 12. Insulation resistance measurement

Unplug the cartridge before performing an insulation resistance measurement in the system, otherwise inaccurate measurements are possible. Re-fit cartridge as 11 above after the insulation resistance measurement.

